

**City of Pawtucket
Zoning Board of Review**

**APPLICATION FOR CONSIDERATION BY THE ZONING BOARD OF REVIEW
(Incomplete applications will not be accepted)**

Date: _____

Dear Members of the Board:

The undersigned hereby petitions the Board of Review to consider the application for

_____ **Dimensional Variance** _____ **Appeal of Zoning Official's Ruling**

_____ **Use Variance** _____ **Special Use Permit**

As allowed under the Zoning Ordinance and hereinafter set forth:

Applicant: _____ **Address:** _____

Phone Number: _____

Owner: _____ **Address:** _____

Phone Number: _____

Lessee: _____ **Address:** _____

Phone Number: _____

1. Location of Premises _____
(Street number) (Street name)

2. Assessor's Plat: _____ **Lot:** _____ **3. Zoning District:** _____

4. Dimensions of Lot: _____
(Frontage) (Depth) (Square footage)

5. Does this application require review before the City Planning Commission, Historic District Commission or Riverfront Commission? _____ **Yes** _____ **NO** if yes, attach copy of approval letter.

6. How long have you owned the above premises? _____

7. Current use of premises: _____ **Proposed use of premise:** _____

8. Size of existing building: _____ **Size of proposed building:** _____

9. Identify by plat and lot other land parcels owned by the applicant which abut the subject property: _____

10. Article, section and subsection of the Zoning Ordinance is the applicant seeking a variance:

Zoning requires: _____

Project proposes: _____

11. What are the unique characteristics of the land or structure that require relief from the Terms of the Zoning Ordinance:

12. Is this condition the result of a prior action taken by the applicant:

13. In the case of a use variance, is the applicant presently denied all beneficial use of the property? Explain: _____

14. In the case of a dimensional variance, is the relief requested necessary to enjoy a legally permitted use? Explain: _____

15. Is the relief sought the least necessary to allow use of the property? Explain:

16. In the case of a special use permit, give the section of the Zoning Ordinance that authorizes a special use permit for the proposed use: _____

Does the proposed use meet all the conditions set forth in Section 410-60 of the Zoning Ordinance: _____ Yes _____ NO **Attach copy of the conditions of 410-60.**

If no, please explain: _____

17. Is this application for new or replacement signage? _____ Yes _____ No

If yes, list building frontage _____

And list by type and size all signs on the premises: _____

18. Will the granting of the request by the applicant change the character of the surrounding area or impair the intent of the Zoning Ordinance or the 2003 Comprehensive Plan:

Respectfully submitted,

Signature: _____

Address: _____

STATE OF RHODE ISLAND

Providence County

In Pawtucket in said County, on the _____ day of _____, the year _____ A.D., before me personally appeared the above named _____ and made an oath that the foregoing is true to the best of his/her knowledge, information and belief.

Notary Public

TYPICAL RADIUS PLAN

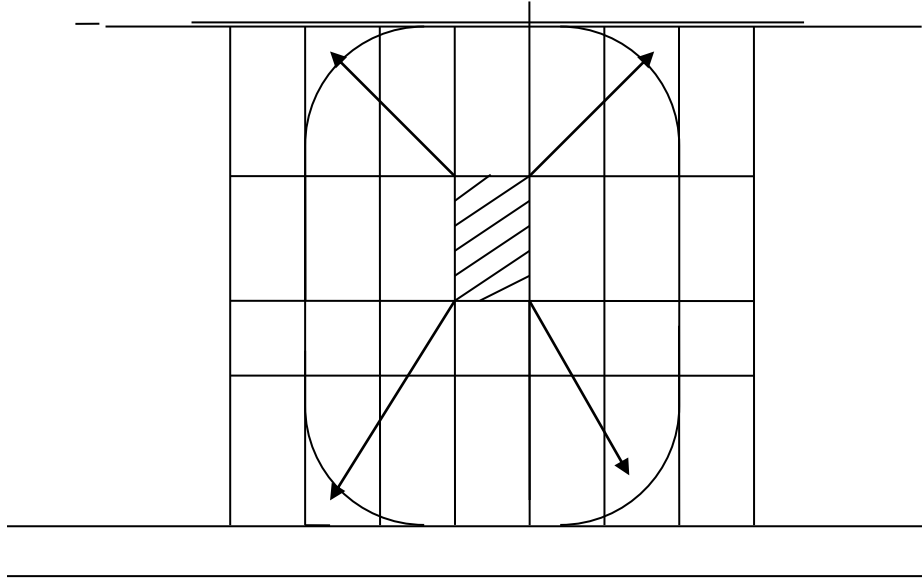

1. Make the radius map
2. List all of the plat and lot numbers that fall within the 200 foot radius
3. List names of property owners and current mailing address

Also, please note that the City of Pawtucket has Land Development and Subdivision Review Regulations which may require additional review of your application.

Subdivision Required

Subdivision is defined as “the division or redivision of a lot, tract, or parcel of land into two or more lots” and is subject to review before the City Planning Commission. If the applicant owns two or more contiguous lots that are substandard (less than the minimum lot size or minimum lot frontage) and the intention is to subdivide a portion of the land for future construction or sale, this is also a subdivision. See Zoning Ordinance Section 410-71.

Site Plan Review Required

Any land development project containing at least 20,000 square feet of land area is subject to land development review before the City Planning Commission. See Zoning Ordinance Section 410-15.1.

If either of the above descriptions applies to your application, you must have your application reviewed by the Department of Planning and Redevelopment, 175 Main Street for a determination. The department staff will review the map and supporting material, advise you whether your application requires review in front of the City Planning Commission, and provide you with the necessary application forms. Unless otherwise

specified, applications requiring review before the Zoning Board of Review will not be heard without prior review and approval by the City Planning Commission.

**ZONING BOARD OF REVIEW REQUIREMENTS
CITY OF PAWTUCKET
EFFECTIVE 2/9/04**

All applications to the Zoning Board of Review under this ordinance must be submitted to this office **COMPLETE** with the following materials:

For **ALL** applications

- Completed application form
- Authorization from owner – if the applicant is a tenant, then a letter of authorization to make the application must be obtained from the owner
- Radius plan that shows all properties within 200 feet of the subject property
- Typed list of names and current mailing addresses of all property owners within the 200 foot radius. (printed labels are preferred)
- Designation of attorney form must be completed with/without an attorney
- Required maps
 - a. All principle and accessory structures must be outlined and distances measured to the side, front, and rear lot lines. Dimensions must be noted on drawings.
 - b. On adjacent land parcels, show building outline and estimate distance if within fifteen (15) feet from subject property line. (Note type of structure – residential, commercial, accessory). All applicants are advised not to trespass on other private property without permission.
 - c. Present and proposed parking spaces and landscaping. For large areas, provide number of spaces per lot and total area. Drawing must be to scale.
 - d. For new construction (*): front and side elevation drawings and floor plan.
 - e. For sign applications, provide information on number, type and dimensions of existing signs. Use definitions of sign type from Zoning Ordinance, Section 410-85. Also, provide frontage dimensions of principal building which is essential for determining allowed sign area.

Map size requirements:

Lot size	Scale
10,000 sq. ft. or less	1" = 20 feet
Lots over 10,000 sq. ft.	1" = 40 feet

Sign details, where applicable ¼" = 1'

- 8 copies of entire application plus the notarized original
- Application fee of \$500.00 made payable to the City of Pawtucket

(*) The Board has determined that if a petition to legitimize an illegal unit is to be treated as if it is new construction.

In addition to the above requirements:

Special Use Permits

- **Attach a copy of conditions from Section 410-60 of the Zoning Ordinance and an explanation of how applicant proposes to meet all conditions.**

Applications requiring approval from other City Commissions or Boards

- **Letter of approval from relevant City Board Commission**

**PAWTUCKET ZONING BOARD OF APPEALS
GENERAL PROCEDURES FOR PUBLIC HEARINGS**

- 1. The Chairman of the Zoning Board of Appeals will call the meeting to order. The Chairman will read the description of each application scheduled for public hearing, and ask if there are any objectors to that application.**

IF YOU ARE ATTENDING THE PUBLIC HEARING TO OBJECT TO THE APPLICATION, PLEASE SIMPLY RAISE YOUR HAND AT THIS TIME, TO INDICATE THAT YOU ARE AN OBJECTOR. You will be allowed to voice your objection when the application is heard.

If you wish to speak IN FAVOR of the application, you need not notify the Board at this time. You may testify on behalf of the application when it is called for public hearing, after the applicant has testified.

- 2. Applications with no objectors are considered FORMAL, and will be heard, in numerical order, before applications for which there are objectors.**
- 3. in special circumstances, an applicant may request that the application be tabled, or postponed until a later date, usually on month. In that case, the Chairman will read the application description, then inform the Board and public that the applicant requests the application be tabled.**
 - a) Notice of the reschedule hearing date will be sent to abutting neighbors at least fourteen (14) days before that public hearing, as provided in the Zoning Ordinance.**
- 4. When FORMAL application is called by the Chairman for public hearing.**
 - a) The applicant and/or the applicant's representative will step forward, be sworn in, state his/her name and address for the record, and testify as to the proposed plan(s) for the property. The applicant may present documents or information which he/she feels is helpful or necessary for the Board to consider in making its decision.**
- 5. The Board will recess for a short break after all formal applications are heard.**
- 6. When an OBJECTED application is called by the Chairman for public hearing.**
 - a) As previously described, the applicant will testify under oath. The Chairman will then call for objectors to come forward, ONE AT A TIME.**
 - b) Each objector will be sworn in, state his/her name and address for the record, and testify as to the reason(s) for the objection. Objectors are asked**

to be as clear and specific as possible about the nature of the objection. Objectors may present documents or information which they feel would be helpful or necessary for the Board to consider in making its decision.

- 7. The Zoning Board of Appeals does not decide an application on the evening of the public hearing. The Zoning Board of Appeals reconvenes on the following Tuesday, one week after the public hearing, to discuss and decide each application, in the order in which they were heard. Applicants, objectors, and any other interested parties are invited to attend the meeting. However, no additional testimony is taken on the evening the Board makes its decision.**
- 8. The minutes reflecting the vote of the board is available by telephone on the Wednesday morning after the decisions are made. The official written decision is filed in land evidence records which may be checked through their database. The decisions are also posted in two locations at City Hall.**
- 9. Appeal of a Zoning Board decision to Superior Court may be may in accordance with Section 45-24-63 of the Pawtucket Zoning Ordinance, available for review in the City Clerk's office.**
- 10. Any decision evidencing the granting of a variance, modification, or special use shall also be recorded in the land evidence records of the City of Pawtucket.**

